

**FINISH CODES**

**FILL IN SHADED AREAS TO COMPLETE THE PART DESCRIPTION**

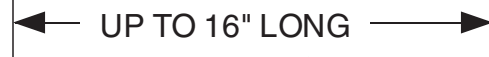

SEE NOTE 3

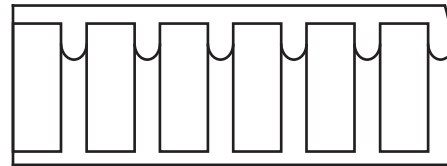
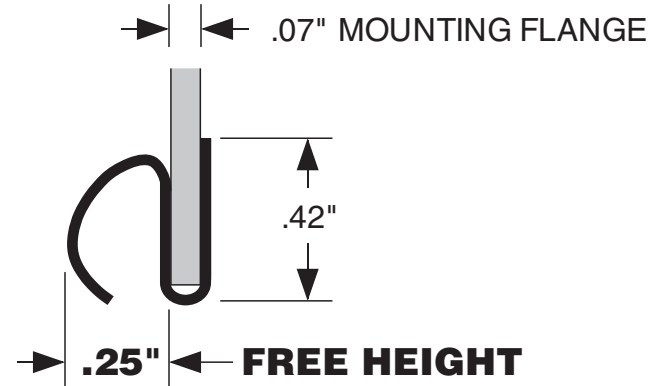

**TECH-ETCH MANUFACTURING PART NUMBER**

187KC080 - - (PROFILE) - (LENGTH) - (FINISH)
<b>LENGTH CALCULATOR FOR PART NUMBER ABOVE</b> CLICK HERE FOR STOCK LENGTH, OR ENTER NUMBER OF FINGERS HERE:

**NOTES:**

1. MATERIAL ~~W/C~~ ~~W/B~~ ~~W/Cu~~, C17200 HARDENED.
2. FINISH: AS SPECIFIED - SEE TOP LEFT.
- 3 STRIPS MAY BE SUPPLIED CUT TO ANY FULL FINGER INCREMENT.  
ALLOWED LENGTHS = NUMBER OF FINGERS MINUS SLOT WIDTH.
4. UNLESS OTHERWISE SPECIFIED DIMENSIONS ARE IN INCHES.

UNLESS OTHERWISE SPECIFIED ALL TOLERANCES TO BE:

- .XX ±.02
- .XXX ±.005
- .X ±.005/in.

**Tech-Etch**

45 Aldrin Road, Plymouth, MA 02360  
 TEL 508-747-0300 • FAX 508-746-9639  
 sales@tech-etch.com • www.tech-etch.com

SCALE: <b>200%</b>	CATALOG PROFILE: <b>187KC080</b>
DATE: <b>5/1/03</b>	PART NAME: <b>Clip-on Reverse Bend Contacts</b>
CUSTOMER PART NUMBER:	