

**FINISH CODES**

**FILL IN SHADED AREAS TO COMPLETE THE PART DESCRIPTION**

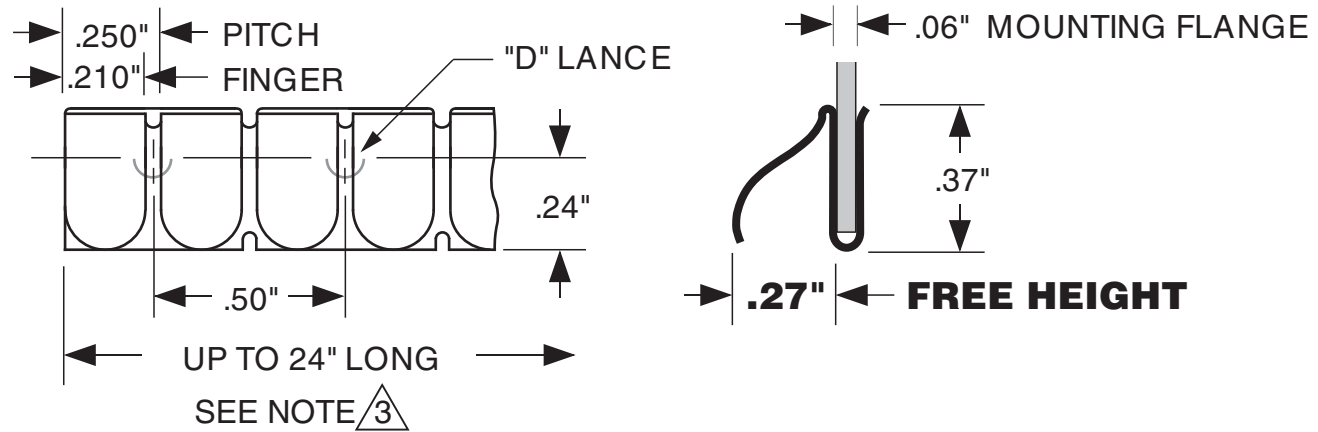

**TECH-ETCH MANUFACTURING PART NUMBER**

250K2C070L	-	-
(PROFILE)	-	(LENGTH) - (FINISH)
<b>LENGTH CALCULATOR FOR PART NUMBER ABOVE</b>		
CLICK HERE FOR STOCK LENGTH,		
OR ENTER NUMBER OF FINGERS HERE:		

**NOTES:**

1. MATERIAL: ~~Al-60~~ ~~Al-60~~ Cu, C17200 HARDENED.
2. FINISH: AS SPECIFIED - SEE TOP LEFT.
3. STRIPS MAY BE SUPPLIED CUT TO ANY FULL FINGER INCREMENT. ALLOWED LENGTHS = NUMBER OF FINGERS MINUS SLOT WIDTH.
4. UNLESS OTHERWISE SPECIFIED DIMENSIONS ARE IN INCHES.

UNLESS OTHERWISE SPECIFIED ALL TOLERANCES TO BE: .XX ±.02 .XXX ±.005 .X ±.005/in.	<b>Tech-Etch</b> 45 Aldrin Road, Plymouth, MA 02360 TEL 508-747-0300 • FAX 508-746-9639 sales@tech-etch.com • www.tech-etch.com
SCALE: <b>200%</b>	CATALOG PROFILE: <b>250K2C070L</b>
DATE: <b>5/1/03</b>	PART NAME: <b>Clip-on Reverse Bend Contacts</b>
CUSTOMER PART NUMBER:	