

FINISH CODES

FILL IN SHADED AREAS TO COMPLETE THE PART DESCRIPTION

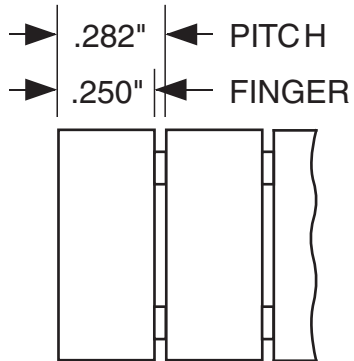

SEE NOTE ³

LENGTHS UP TO 4 FINGERS

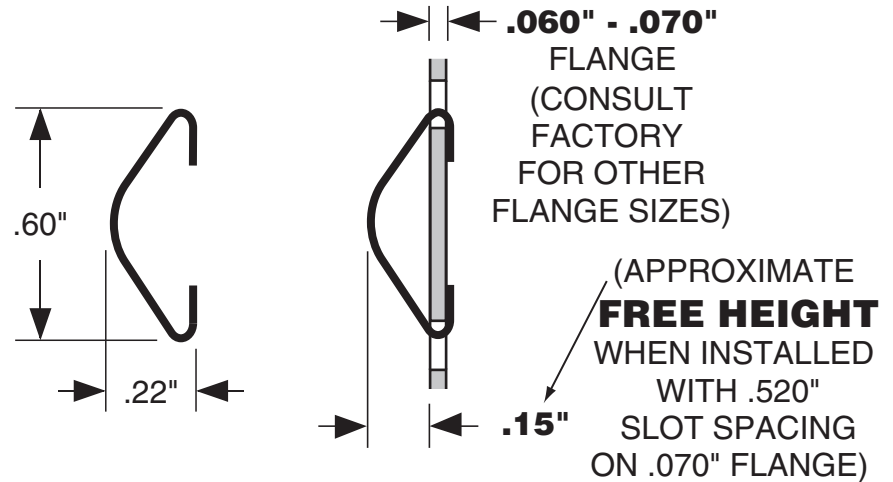

TECH-ETCH MANUFACTURING PART NUMBER

250S60	-	-
(PROFILE)	-	(LENGTH) - (FINISH)
CHOOSE	STANDARD THICKNESS OR	"TF" THICKNESS
LENGTH CALCULATOR FOR PART NUMBER ABOVE		
CLICK HERE FOR STOCK LENGTH, OR ENTER NUMBER OF FINGERS HERE:		

NOTES:

1. MATERIAL ~~Al-6061~~ ^{Al-6061} Cu, C17200 HARDENED.
2. FINISH: AS SPECIFIED - SEE TOP LEFT.
- ³ STRIPS MAY BE SUPPLIED CUT TO ANY FULL FINGER INCREMENT.
ALLOWED LENGTHS = NUMBER OF FINGERS MINUS SLOT WIDTH.
4. UNLESS OTHERWISE SPECIFIED DIMENSIONS ARE IN INCHES.

UNLESS OTHERWISE SPECIFIED ALL TOLERANCES TO BE:

- .XX ±.02
- .XXX ±.005
- .X ±.005/in.

Tech-Etch

45 Aldrin Road, Plymouth, MA 02360
TEL 508-747-0300 • FAX 508-746-9639
sales@tech-etch.com • www.tech-etch.com

SCALE:

200%

CATALOG PROFILE:

250S60

DATE:

5/1/03

PART NAME:

Snap-on Symmetrical Slot/Edge Mount

CUSTOMER PART NUMBER: