

FINISH CODES

FILL IN SHADED AREAS TO COMPLETE THE PART DESCRIPTION

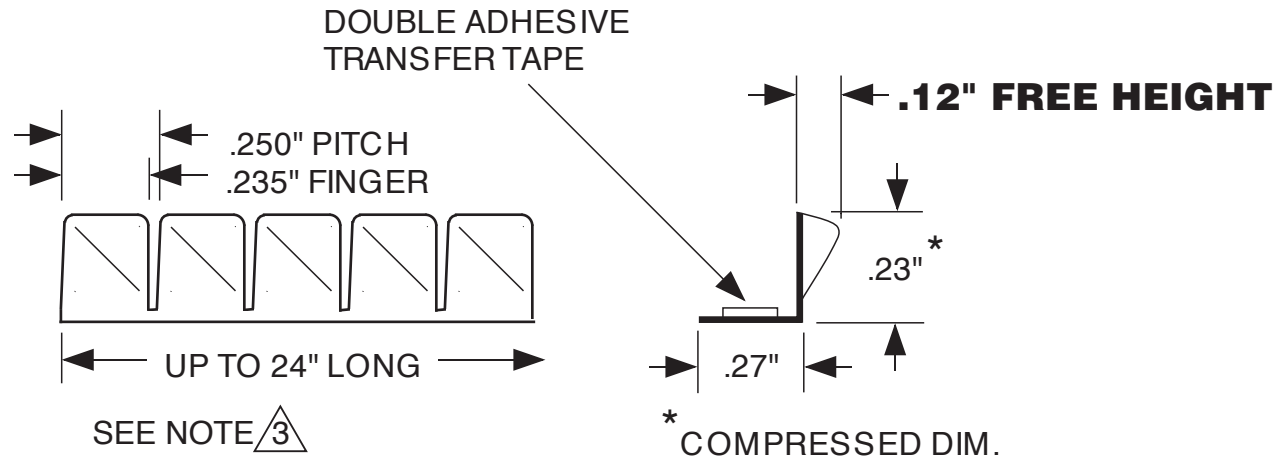

TECH-ETCH MANUFACTURING PART NUMBER

250T90 - -
(PROFILE) - (LENGTH) - (FINISH)
LENGTH CALCULATOR FOR PART NUMBER ABOVE
CLICK HERE FOR STOCK LENGTH, OR ENTER NUMBER OF FINGERS HERE:

NOTES:

1. MATERIAL .003" BeCu, C17200 HARDENED.
2. FINISH: AS SPECIFIED - SEE TOP LEFT.
- $\triangle 3$ STRIPS MAY BE SUPPLIED CUT TO ANY FULL FINGER INCREMENT.
ALLOWED LENGTHS = NUMBER OF FINGERS TIMES PITCH.
4. UNLESS OTHERWISE SPECIFIED DIMENSIONS ARE IN INCHES.

UNLESS OTHERWISE SPECIFIED ALL TOLERANCES TO BE:

- .XX ±.02
- .XXX ±.005
- .X ±.005/in.

Tech-Etch

45 Aldrin Road, Plymouth, MA 02360
TEL 508-747-0300 • FAX 508-746-9639
sales@tech-etch.com • www.tech-etch.com

SCALE: 200%

CATALOG PROFILE: 250T90

DATE:

PART NAME: Stick-on Twisted Contacts

CUSTOMER PART NUMBER: