

**FINISH CODES**

**FILL IN SHADED AREAS TO COMPLETE THE PART DESCRIPTION**

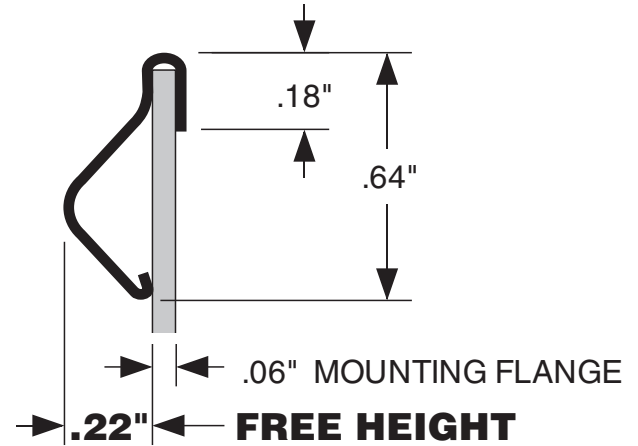
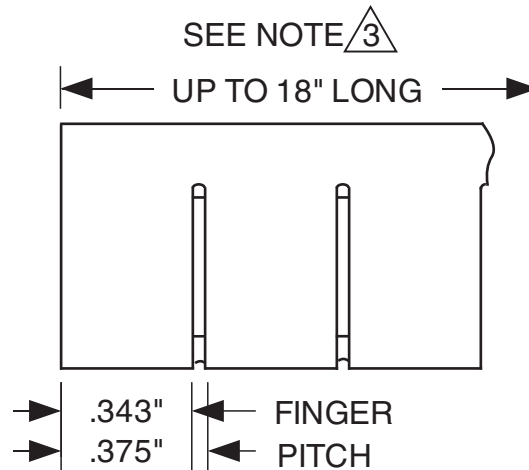

**TECH-ETCH MANUFACTURING PART NUMBER**

375P64C070 - -			
(PROFILE)	-	(LENGTH)	- (FINISH)
<b>LENGTH CALCULATOR FOR PART NUMBER ABOVE</b>			
CLICK HERE FOR STOCK LENGTH,			
OR ENTER NUMBER OF FINGERS HERE:			

**NOTES:**

1. MATERIAL: ~~Al-10%Ni~~ BeCu, C17200 HARDENED.
2. FINISH: AS SPECIFIED - SEE TOP LEFT.
- <sup>3</sup> STRIPS MAY BE SUPPLIED CUT TO ANY FULL FINGER INCREMENT. ALLOWED LENGTHS = NUMBER OF FINGERS MINUS SLOT WIDTH.
4. UNLESS OTHERWISE SPECIFIED DIMENSIONS ARE IN INCHES.

UNLESS OTHERWISE SPECIFIED ALL TOLERANCES TO BE: .XX ±.02 .XXX ±.005 .X ±.005/in.	 45 Aldrin Road, Plymouth, MA 02360 TEL 508-747-0300 • FAX 508-746-9639 sales@tech-etch.com • www.tech-etch.com
SCALE: 200%	CATALOG PROFILE: 375P64C070
DATE: 5/1/03	PART NAME: Clip-on Soft No-snap Fingers
CUSTOMER PART NUMBER:	